



香港天宝实业有限公司
KINGMAX HOBBY Co., Limited

产品规格书

产品编号: ITEM NO.	GDD6540
产品名称: ITEM NAME:	Digital standard servo
产品图片: PRODUCT IMAGE:	

制订 (IMPLEMENTER)	审核 (CHECK)	批准 (APPROVAL)	日期 (DATE)

PROFESSIONAL SERVOS MANUFACTURER

ADD: Area 39, Wei Jian 2nd Road, Chashan Industrial, Chashan Town, Dong Guan City, Guang Dong Province, China. (zip code:523382)

TEL: 0769-86866722 FAX:0769-81192252

[Http://www.kingmaxhobby.com](http://www.kingmaxhobby.com) Email : sales@kingmaxhobby.com

1. 使用環境條件

Apply Environmental Condition :

No.	項目	規格
1-1	保存溫度 Storage Temperature Range	-20℃ ~ 60℃
1-2	操作溫度 Operating Temperature Range	-10℃ ~ 50℃
1-3	操作電壓 Operating Voltage Range	5.0V~8.4V

2. 測試環境

Standard Test Environment :

2-1	測試環境 Standard Test Environment	每一个检查必须是正常的温度和湿度进行测量，温度 $25 \pm 5^\circ\text{C}$ ，相对湿度 $65 \pm 10\%$ ，在按照本规范的标准测试条件下判断特征。
-----	-----------------------------------	---

3. 外觀檢查

Appearance Inspection :

No.	項目	規格
3-1	外觀尺寸 Outline Drawing	40*20*40.2
3-2	外觀 Appearance	无损坏，不允许影响功能
3-3	壽命 Life Time	>50000次/负载(sub/load)

4. 電氣特性

Electrical Specification (Function of the Performance) :

No.	Item	5.0V	6.0V	7.4V	8.4V
4-1	空載轉速 Operating speed(at no load)	0.29S/60°	0.24S/60°	0.20S/60°	0.18S/60°
4-2	空載最大電流 Running current(at no load)	600mA	700mA	900mA	1000mA
4-3	堵轉扭力 Stall torque(at locked)	30.0kg.cm	36.0kg.cm	40.0kg.cm	44.0kg.cm
4-4	堵轉最大電流 Stall current (at locked)	3.3A	4.2A	5.5A	6.0A
4-5	最大工作扭矩 Maximum working torque	19.0kg.cm	23.5kg.cm	26.0kg.cm	28.5kg.cm
4-6	最大工作電流 Maximum working current	2.7A	3.5A	4.5A	5.0A
4-7	額定工作扭力 Rated working torque	9.0kg.cm	9.5kg.cm	10.5kg.cm	11.0kg.cm
4-8	額定工作電流 Rated working current	1.2A	1.4A	1.5A	2.2A
4-9	待機電流 Idle current (at stopped)	10mA	10mA	10mA	10mA

Product Name

伺服器

Model No.

GDD6540

Version

Page

1

5. 機械特性

Mechanical Specification :

No.	項目	規格
5-1	外觀尺寸 Overall Dimensions	40*20*40.2mm
5-2	機構極限角度 Limit angle	360°
5-3	重量 Weight	65±1g
5-4	導線規格 Connector wire gauge	#22 AWG
5-5	導線長度 Connector wire length	240 ±5 mm
5-6	花鍵 Spline	φ 5.90 25T
5-7	舵片種類 Horn type	一字, 半一字, 米字, 圓盤
5-8	減速比 Reduction ratio	
5-9	馬達類型 Motor	鐵芯/DC
5-10	角度傳感器 Angle sensor	電位器/Potentiometer
5-11	軸承 Bearing	2BB
5-12	齒輪材料 Gear	金屬/Metal
5-13	外殼材料 Case	塑膠+鋁/Plastic+Aluminium
5-14	防水 Waterproof	Yes
5-15	電源正極 Positive pole	紅色/Red
5-16	電源負極 Negative electrode	棕色/Brown
5-17	信號線 Signal	黃色/Yellow

Product Name

伺服器

Model No

GDD6540

Version

Page

2

6. 控制特性

Control Specification :

No.	項目	規格
6-1	控制系統 Control system	改变脉冲宽度
6-2	放大器種類 Amplifier type	数字控制器
6-3	操作角度 Operating travel	90° (在1000→2000 μ sec)
6-4	中立位置 Neutral position	1500 μ sec
6-5	脈波訊號虛位 Dead band width	2 μ sec
6-6	旋轉方向 Rotating direction	逆时针 (在1500→2000 μ sec)
6-7	脈波寬度範圍 Pulse width range	500→2500 μ sec
6-8	可作動角度範圍 Maximum travel	大约 180° (在 500→2500 μ sec)

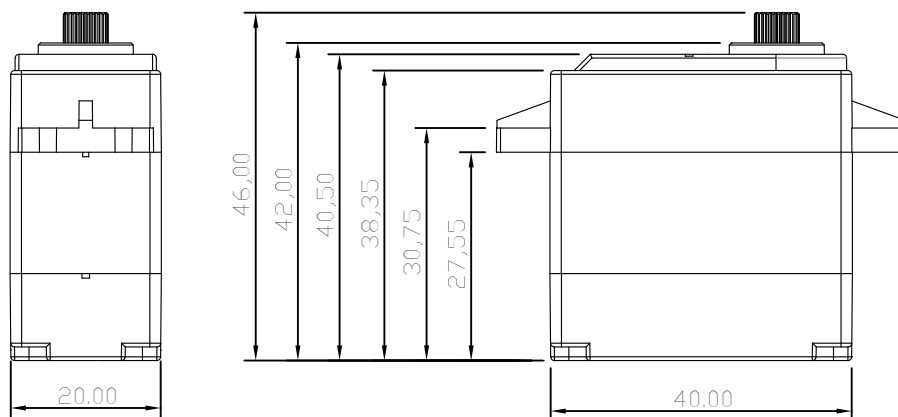
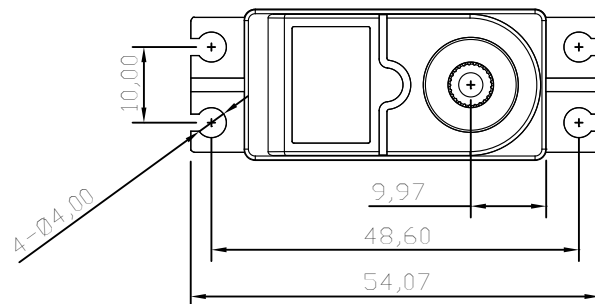

Product Name

伺服器

Model No.
GDD6540

Version

Page

3